



Board of Park Commissioners Approval Form

PROJECT NAME: McMillen Park EV Charging Station Lease Agreement

PROJECT NUMBER: n/a

REQUEST

Scope of Work/Project Narrative:

This is a lease agreement between the City of Fort Wayne Board of Public Works and the Board of Park Commissioners for the use of a portion of land located in McMillen Park to install two new electric vehicle charging stations. The proposed location is in the parking lot west of the McMillen Community Center. Each charging station serves two vehicles, thus requiring the use of four parking spaces to be designated for electric vehicles. Any expenses associated with the installation and operation of the chargers will be solely the responsibility of the City and not of the Board of Park Commissioners. The terms of the agreement are for five years, with the option to renew and the end of that period.

Board Approval/Purpose:

The total for these services, as outlined on the lease agreement, is \$ _____ 0 .00.

At this time, I would like to request approval of this lease agreement.

The Fort Wayne Parks and Recreation and the Board of Park Commissioners, met to host their regularly scheduled monthly Board meeting on **November 10, 2022**, to approve the lease agreement for the above-referenced project in the amount of \$ **0.00**.

We, the Board of Park Commissioners, on the date stated do ATTEST, sign to the above-referenced and attached documents, and approve as presented.

William Zielke, President

Justin Shurley, Vice President

Cory Miller, Commissioner

Richard Briley, Commissioner

Steve McDaniel, Director / Board Secretary

ELECTRIC VEHICLE CHARGING STATION HOST LEASE AGREEMENT

THIS ELECTRIC VEHICLE CHARGING STATION LEASE AGREEMENT (“Agreement”) is made on the ____ day of November 2022, by and between the CITY OF FORT WAYNE, an Indiana Municipal Corporation (the “City”), by and through its Board of Public Works, and _The Board of Park Commissioners (“Site Owner”) owning property at **3901 Abbot Street, Fort Wayne, IN 46806** _, individually referred to as “Party” and collectively referred to as “Parties.”

WHEREAS, the Indiana Volkswagen Environmental Mitigation Trust Program (“Trust Program”) administrated by Indiana Department of Environment Management (“IDEM”) is focused on improving Indiana’s electronic vehicle (“EV”) charging network by providing grants to applicants focused on a single statewide, regional, local or individual EV charging network installations;

WHEREAS, the City has received a grant from IDEM and desires to install EV charging stations at multiple locations throughout the City; and

WHEREAS, by installing EV charging stations on the Premises, as defined herein, will provide value to the Site Owner by attracting electric vehicle owners and the public to, and providing additionally visibility of, the property;

NOW, THEREFORE, in consideration of the mutual covenants and agreements contained therein, the Parties agree as follows:

- 1. Property.** The Site Owner is the owner of the property commonly known as **McMillen Park Community Center, 3901 Abbott St, Fort Wayne, IN 46806**. Additionally, described as four (4) total parking spaces and property adjacent for equipment on the south side of the golf clubhouse. Further detailed in Exhibit “A,” attached hereto and made a part hereof (the “Property”).
- 2. Premises.** The Site Owner hereby leases at no cost to the City approximately (720 SQ FT) or four (4) parking spaces and approximately (175 SQ FT) square feet of space immediately adjacent to parking spaces as depicted in Exhibit “A,” attached hereto, together with all related equipment, in order for City to construct and operate Charging Station(s) at the City’s own expense, for public use to the extent necessary to provide EV charging services (the “Premises”). For purposes of this Agreement, “Charging Station” shall mean all electrical and mechanical equipment, hardware, and software installed by the City, electrical wiring and/or cabling, meters and disconnect panels, equipment infrastructure (“Trade Fixtures”), the City’s signage and all supporting equipment, including without limitation concrete pads, protective bollards, and, if elected to be constructed by the City, a canopy covering the Premises. The parking area, drives, green spaces and related improvements that are part of each Site Owner’s Property are hereinafter referred to as the "Common Area."
- 3. Possession.** The first date when the City may enter the Premises and begin construction (as set forth in Paragraph 7), and thereafter operate the Charging Stations is November 1, 2022.

4. **Term.** The term of this Agreement begins on the date this Agreement is approved and signed by the City of Fort Wayne Board of Public Works and end five (5) years from that date (“Term”).
5. **Extension.** Upon mutual agreement, the Parties shall have the right to extend the Agreement an additional period of five (5) years (the “Renewal Term”). To extend the initial Term, the Party wishing to extend the Agreement shall deliver written notice of such extension to the other Party no later than ninety (90) days prior to the expiration of the initial Term. In the event that the Parties agree to extend the Agreement, this Agreement shall continue based upon the identical terms and conditions hereof.
6. **Expansion Option.** The City shall have the right to lease the additional adjacent square feet identified in Paragraph 2 for EV charging parking spaces upon the same terms and conditions as the Premises. In the event the City wishes to exercise such option to expand the additional parking spaces, it shall provide written notice to the Site Owner. The Site Owner shall review and have the right to approve or deny additional spaces and shall permit the City to prepare plans and specifications for such additional space, pull the permits, and upon receipt of permits, build out such additional spaces with additional charging stations, at which time, such additional space shall be part of the Premises.
7. **Construction on the Premises.**
 - a. **Installation.** Upon execution of this Agreement, Site Owner shall deliver possession of the Premises to the City and the City shall, at its sole cost and expense, construct the improvements described in and pursuant to the procedures set forth in Exhibit “B” attached hereto and made a part hereof. The design, make, model, and manufacturer of the City charging stations and their number and approximate locations are specified in Exhibit “A & B”. The City, at any time and for any reason during the term of this Agreement, may elect to upgrade, revise, alter, or swap any Charging Station installed in the Premises.
 - b. **Construction.** The City is solely responsible for supervising the construction and installation of the Charging Station, and shall have control over construction, scheduling, and installation means, methods, techniques, sequences, and procedures, including the coordination of all work. Before commencing installation of the Charging Station at the Premises, the City shall give a copy of the anticipated construction schedule and installation plans to Site Owner for its approval, which approval shall not be unreasonably withheld, conditioned, or delayed. No work will begin until plans have been approved by Site Owner and all applicable permits and certifications have been obtained. Once approved, the City will, at its sole cost and expense, oversee and manage the installation of the Charging Station, including the hiring and coordination of all vendors and contractors; the installation of electrical equipment, utility lines, hardware, and software; site preparation, trenching, repaving, and landscaping; and installation of all the City branded signage. Site Owner shall allow the City and the City’s agents to stage equipment in reasonable proximity to the Premises to facilitate the City’s construction at the Property;

provided such staging shall not unreasonably interfere with Site Owner's use of the Property. The City shall be permitted to reconfigure the existing parking spaces to meet the needs of the City and the City's end users. For the avoidance of doubt, reconfiguring of parking spaces shall include, among other things, re-striping or signage in the areas shown on Exhibit "A." And, if approved by the Owner the City may reduce the number of striped parking spaces, if necessary, to promote the efficient and legal use of the EV charging parking spaces.

- c. Permits. The City will, at its sole cost and expense, obtain from applicable governmental authorities all licenses, permits, or other approvals required to install the Charging Station, and Site Owner will reasonably cooperate upon request with the City's efforts to do so.
- 8. Ownership by the City.** The City shall either own or have a valid leasehold interest in the Charging Station, and as such, as between the Site Owner and the City, the Charging Station shall remain the sole property of the City at all times, and the City shall have the right to remove all or a portion of the Charging Station at any time during the term of this Agreement, whether or not the Charging Station is considered a fixture and attached to the Premises under applicable laws. If the parties do not renew the Agreement, and Site Owner does not wish to take control of the Charging Stations, the City shall remove all above ground equipment, known as Trade Fixtures and leave all underground facilities, which include conduit and power feed. If the parties do not renew the Agreement and Site Owner wishes to take control of the Charging Stations, the infrastructure (as defined in "Exhibit A & B") shall become the property of Site Owner at no additional cost and Site Owner shall assume all responsibility of Infrastructure, fixtures, equipment and operating costs associated with the normal operation of the Charging Stations.
- 9. Operation and Maintenance.** At its sole cost and expense, the City shall be responsible for maintaining the Charging Stations and Site Owner shall not have any liability for damage to the Charging Stations unless such damage is caused by the Site Owner's gross negligence or willful misconduct. Notwithstanding the foregoing, Site Owner's normal responsibility to maintain the common areas of the Property shall also apply to the Premises, such as for debris and garbage collection and removal. Site Owner agrees to coordinate any parking lot maintenance with the City to ensure that charging stalls remain available as much as is reasonably feasible. The City may, in its discretion and at its sole cost, install security cameras and other equipment to monitor the Premises from off-site. All site equipment installed in relation to the charging infrastructure shall be maintained in good condition for the entire term of the Agreement.
- 10. Right to Tow.** The City or property owner retains the right to remove any vehicle from the Premises at any time and for any reason at the City's sole cost, in accordance with applicable law. The City shall post signage designating parking spaces as EV Charging Capable.
- 11. Operation of Charging Stations.** Site Owner shall have no right to any revenues or payments relating to the operation of the Charging Stations installed at the Premises, either from the City or from any third-party.

12. Utility Availability. The City shall be responsible for all electricity costs of the Charging Station. The City shall, at its sole expense, ensure that the Charging Station contains separately-metered electricity with the City as the customer of record for such meter. The City may charge its end users for electrical usage. Site Owner shall cooperate with the City to obtain electricity and any other utilities necessary to operate the Charging Station, including by granting appropriate easements to local utility providers; provided, however, that the Site Owner is not required to pay money to satisfy the requirements of the utility provider or the City associated with the provision of such utilities. Neither the City nor the Site Owner has any responsibility or liability for interruption, curtailment, failure, or defect in the supply or character of utilities furnished to facilities or equipment located at the Premises, unless the cause of the interruption is covered by the Party's indemnity provisions.

13. Site Owner Covenants. Site Owner represents that it is the owner of the Property and Premises and that this Agreement does not violate any agreement, lease or other agreement of Site Owner. Site Owner shall not take any action that would impair or interrupt the use of the Premises. Site Owner agrees to notify the City within a commercially reasonable time if (a) it has knowledge of third-parties impairing or misusing the Premises or Charging Stations, or (b) it obtains knowledge of a needed repair to the Premises or Charging Stations. If motorists who do not utilize the Charging Stations repeatedly park in the parking spaces in the Premises, thereby impairing use of the Charging Stations, then the Parties shall together determine and implement an appropriate and effective strategy for preventing such impairment, including, without limitation, alternative signage and painted asphalt. Site Owner shall use commercially reasonable efforts to actively monitor the Premises to ensure that use of the Charging Stations is not impaired.

14. Termination.

- a. By City. City shall have the right to terminate this Agreement at any time upon sixty (60) days prior written notice. In connection with any early termination, the City shall comply with the Surrender obligations set forth below.
- b. By Site Owner For Cause. This Agreement may be terminated by the Site Owner if the City breaches or fails to perform any of its obligations in any material respect, and such breach or failure continues uncured for sixty (60) days after receipt of written notice.
- c. Surrender. Promptly following the expiration or termination of this Agreement, City shall remove the Charging Station, including the Trade Fixtures from the Premises and restore the Premises to its former condition, excluding ordinary wear and tear; provided, however, that any underground electrical wiring shall be capped off and secured, but not removed. For the avoidance of doubt, City will not remove any equipment installed by the electric utility having jurisdiction.
- d. No Further Obligations. Upon any termination pursuant to this Section, both Parties are relieved of any further obligations contained in this Agreement, except for those that by their nature survive or may require performance after termination (e.g., indemnity).

15. Alterations. Except for the construction, maintenance of the Charging Stations, and the signage, the City shall not make any alterations, changes in or additions to the Premises without the prior written consent of the Site Owner, which such consent shall not be unreasonable withheld.

16. Assignment. In the event of a sale or transfer of the Property or Premises while the Agreement is in effect, this Agreement, including Site Owner's obligations and duties hereunder, shall be conveyed with the Property or Premises. Notwithstanding the above, the Site Owner shall not assign this Agreement without the prior written consent of the City, which such consent shall not be unreasonably withheld. This Agreement shall be binding upon and shall inure to the benefit of the parties hereto and their respective successors and permitted assigns.

17. Default. After material breach by either party to this Agreement, the other nonbreaching party can terminate this Agreement on ten (10) days' written notice if such breaching party has not cured such default within thirty (30) days after first notice of such breach by the non-defaulting party. Neither party shall be liable for, and each party hereto expressly releases the other party from, indirect, consequential, special, or punitive damages, including, without limitation, lost sales or profits damages.

18. Notice. Any notice provided or permitted to be given under this Agreement must be in writing and be served either by (a) deposit in the mail, addressed to the party to be notified, postage prepaid, and registered or certified, with a return receipt requested, or (b) deposit with an internationally-recognized overnight delivery carrier, with notice of delivery to the recipient party. Notice given by registered or certified mail or overnight carrier shall be deemed delivered and effective on the date of delivery shown on the return receipt or proof of receipt. For purposes of notice the addresses of the parties shall be as follows:

If to the City:

Board of Public Works
200 East Berry Street, Suite 210
Fort Wayne, IN 46802

If to the Site Owner:

Board of Park Commissioners
705 E State Blvd.
Fort Wayne, IN 46805

Each party may change its address for notice by giving notice thereof to the other party.

19. Signage. City signage at the Premises may be required or desired. All signing identification, including way-finding signage, for each Premises and the placement will be subject to Site Owner's prior approval, which shall not be unreasonably withheld. All costs

related to signage for each Premises shall be paid by the City. The City shall obtain any necessary permits from governmental authorities for the erection and maintenance of its signs.

20. Indemnification. Except to the extent of any gross negligence or willful misconduct of Site Owner, City hereby agrees to indemnify, hold harmless and defend Site Owner, its managers, members, agents and representatives from all liability, damages, loss, costs and obligations, including, court costs and attorney's fees, on account of or arising out of or alleged to have arisen out of any claim of any third party directly related to the City's use of the Premises.

Except to the extent of any gross negligence or willful misconduct of City, Site Owner hereby agrees to indemnify, hold harmless and defend City, its managers, members, agents and representatives from all liability, damages, loss, costs and obligations, including, court costs and attorney's fees, on account of or arising out of or alleged to have arisen out of any claim of any third party directly related to Site Owner's actions related to the Premises.

21. Destruction. Any partial or total destruction of the Premises shall, at either Party's election within thirty (30) days of such destruction, terminate the Agreement.

22. Insurance. Site Owner shall carry commercial general liability insurance with limits of not less than One Million Dollars (\$1,000,000) for bodily injury or death and property damage and an umbrella insurance policy of not less than Five Million Dollars (\$5,000,000). A certificate evidencing such insurance shall be delivered to the City to the other party hereto as may be requested by the other party hereto. The City may furnish Site Owner with a certificate or other written evidence demonstrating that the City is insured by a self-funded program.

23. Environmental Matters. To the best of Site Owner's knowledge, the Site Owner believes that the Premises shall be delivered free of environmental contamination. The City shall have no liability for any environmental contamination unless caused by the City, its agents, employees or contractors. During the Term, Site Owner is responsible for remediating any pre-existing contamination or any contamination not caused by the City, its agents, contractors or employees, except for disposal of any contaminated materials that may result from the construction of the project and limited to any excavated contaminated soil that will be properly disposed of. The cost to the City of the disposition of any such excavated contaminated soil will be capped at five thousand dollars (\$5,000). The City shall have no liability for diminution in value of the Property as it relates to environmental contamination.

24. Exclusions. Notwithstanding anything herein to the contrary, the City shall not be liable for, and Site Owner expressly releases the City from any claims from, speculative, indirect, consequential or punitive damages, including any lost sales or profits of Site Owner.

25. Force Majeure. Neither party is responsible for any delay or failure in performance of any part of this Agreement to the extent that delay or failure is caused by fire, flood, explosion, war, embargo, government requirement, civil or military authority, act of God, act or omission of carriers or other similar causes beyond the party's control.

26. Governing Law. This Agreement shall be construed in accordance with and governed by the laws of the State of Indiana, notwithstanding its choice of law rules to the contrary or any other state's choice of law rules. Suit, if any, shall be brought in a court of applicable jurisdiction situated in Allen County, Indiana.

27. Amendment. This Agreement may only be amended, modified or supplemented by an agreement in writing signed by each Party.

28. Severability. If any term or provision of this Agreement is invalid, illegal or unenforceable in any jurisdiction, the Parties agree that such provision shall be adjusted or modified by the court to the extent necessary to cure that invalidity, and that such invalidity, illegality or unenforceability shall not affect any other term or provision of this Agreement or invalidate or render unenforceable such term or provision.

29. Authority The person signing this Agreement warrant that they have the authority to sign as, or on behalf of, the part for whom they are signing.

IN WITNESS WHEREOF, the Parties hereto hereby execute this Agreement as of the Effective Date written below.

City of Fort Wayne:

By: _____
Shan Gunawardena, Chair

By: _____
Kumar Menon, Member

By: _____
Chris Guerrero, Member

Date: _____

ATTEST: _____
Michelle Fulk-Vondran, Clerk

**City of Fort Wayne
Board of Park Commissioners**

William Zielke, President

Justin Shurley, M.D., Vice-President

Cory Miller, Commissioner

Richard Briley, Commissioner

Steve McDaniel, Director/Board Secretary

Exhibit "A"



October 13, 2022

This map is intended for general reference purposes only. The information displayed herein is not guaranteed to be completely accurate or all inclusive.

© 2015 City of Fort Wayne

Exhibit "B"



CT4000 Family

ChargePoint® Charging Stations

The CT4000 is the latest generation of ChargePoint charging stations. Refined yet rugged, the CT4000 family sets the industry standard for functionality and aesthetics. A robust cord retraction system comes standard on all CT4000 models to eliminate cords on the ground, and to keep your drivers from having to touch charging cables.

The CT4000 full motion color LCD display instructs drivers and is capable of supporting dynamic updates of custom branded videos and advertisements.

The intelligent power sharing feature of the CT4000 doubles the number of parking spaces served by allowing two charging ports to share a single circuit. Sites with single port EV stations can upgrade to dual port stations without requiring additional electrical services.

All CT4000 models offer one or two standard SAE J1772™ Level 2 charging ports with locking holsters, each port supplying up to 7.2kW.

Available in bollard and wall mount configurations, the CT4000 supports easy installation anywhere. To future proof your investment, all stations are fully software upgradeable over the air.

Corporate Branding and Video Advertising

- + Download full motion colour videos to your stations¹
- + Custom replaceable signage to project your brand
- + Custom "cap" printing available²

Intelligent Power Sharing (patent pending)

- + Reduced installation costs
- + Dynamically share one 32A circuit between two parking spaces
- + Double the number of parking spaces for a given site's power capacity
- + Upgrade a single port station to dual port with no electrical upgrade

Cord Management

- + Keep charging cords off the ground and out of drivers hands
- + Standard on all models
- + Ultra-reliable second-generation gravity operated mechanism
- + Flexible over entire -30°C to +50°C product temperature range

Driver Friendly User interface

- + Instructional video shows how to use the station
- + Multi-language: English, French, Spanish
- + Touch button interface; works in rain, ice and with gloves
- + Backed by ChargePoint's 24/7/365 driver phone support

Energy Measurement and Management

- + Real-time energy measurement
- + 15 minute interval recording
- + Time of Day (TOD) pricing
- + Load shed by % of running average or to fixed power output

The standard *EV Charging Only* sign is easily replaceable with your branding.

The cap of the CT4000 family is also available for custom branding.

The large LCD display provides full motion charging instructions in a clear and simple format. It also allows station owners to deliver advertising messaging.

Driver interaction is supported in any weather by five rugged, back-lit buttons with audio feedback.

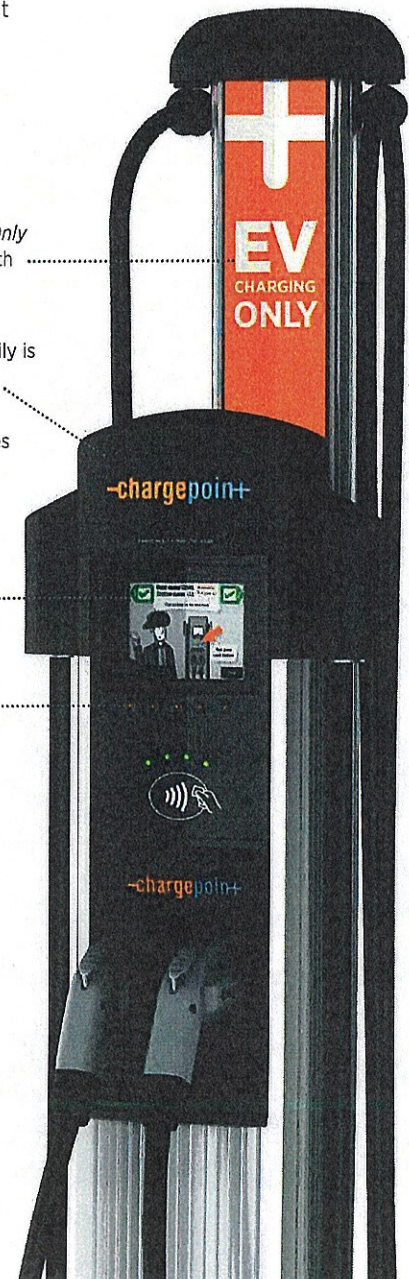

¹ Download fees apply

² Minimum order quantities apply

CT4021 Bollard

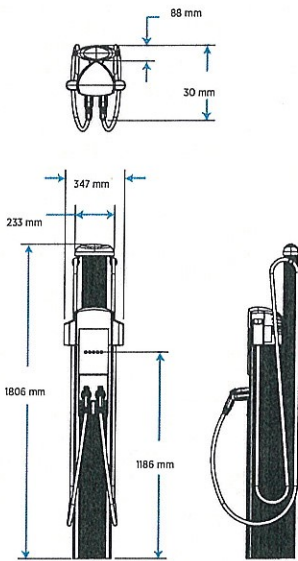

CT4023 Wall Mount

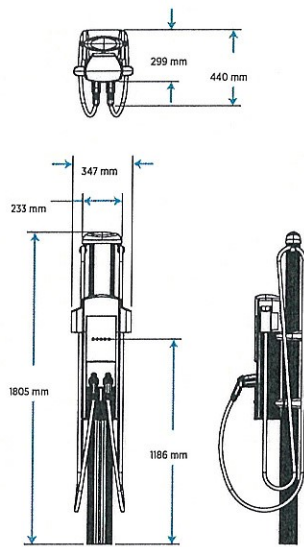

CT4000 Family Specifications

| Electrical Input | Single Port | Dual Port |
|--|--|--|
| AC Power Input Rating - Standard | 230VAC 50Hz single phase @ 30A | 230VAC 50Hz single phase @ 30A x 2 |
| AC Power Input Rating - Power Sharing | n/a | 208/240 VAC 60Hz single phase @ 32A |
| Input Power Connections - Standard | One 32A circuit | Two independent 32A circuits |
| Input Power Connections - Power Sharing | n/a | One 32A circuit |
| Required Service Panel Breaker - Standard | RCBO rated at 32A, Type B, 30 mA trip current | RCBO rated at 32A, Type B, 30 mA trip current x 2 |
| Required Service Panel Breaker - Power Sharing | n/a | RCBO rated at 32A, Type B, 30 mA trip current |
| Wiring - Standard | 3-wire (L, N, Earth) | 5-wire (L1, N1, L2, N2, Earth) |
| Wiring - Power Sharing | n/a | 3-wire (L, N, Earth) |
| Standby Power | 5W typical | |
| Electrical Output | | |
| AC - Standard | 6.9kW (230VAC @ 30A) | 6.9kW (230VAC @ 30A) x 2 |
| AC - Power Sharing | n/a | 6.9kW (230VAC @ 30A) x 1 OR 3.7kW (230VAC @ 16A) x 2 |
| Functional Interfaces | | |
| Plug(s) Type | SAE J1772™ | SAE J1772™ x 2 |
| Charging Cable Length | 18' (5.5 meters) | 18' (5.5 meters) x 2 |
| Overhead Cable Management System | Yes | Yes |
| Card Reader | ISO 15693, 14443 | |
| Locking Holster | Yes | Yes x 2 |
| Safety and Connectivity Features | | |
| Plug-Out Detection | Power terminated per SAE J1772™ specifications | |
| Power Measurement Accuracy | +/- 2% from 2% to full scale (32A) | |
| Power Report/Store Interval | 15 minute, aligned to hour | |
| Local Area Network | 2.4 GHz Wi-Fi (802.11 b/g/n) | |
| Wide Area Network | Commercial GPRS cellular data network | |
| Safety and Operational Ratings | | |
| Enclosure Rating | IP44 | |
| Safety Compliance | IEC 61851-1, -22; IEC 60529 | |
| Surge Protection | 6 kV @ 3000 A per IEC 1000-4-5. In geographic areas subject to frequent thunder storms, supplemental surge protection at the service panel is recommended. | |
| EMC Compliance | AS/NZS CISPR22:2009 | |
| Operating Temperature | -22°F to 122°F (-30°C to +50°C) | |
| Operating Humidity | up to 85% @ 122°F (+50°C) non-condensing | |
| Non-Operating Humidity | up to 95% @ 122°F (+50°C) non-condensing | |
| Terminal Block Temperature Rating | 221°F (105°C) | |
| Maximum Charging Stations per 802.11 Radio Group | 10. Each station must be located within 150 feet (45 metres) "line of sight" of a gateway station. | |

ChargePoint, Inc. reserves the right to alter product offerings and specifications at any time without notice, and is not responsible for typographical or graphical errors that may appear in this document.

CT4021 Bollard charging station

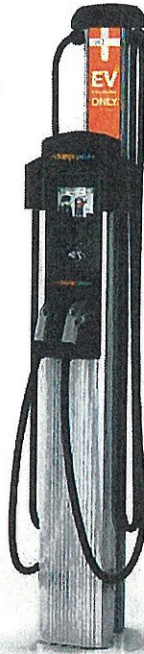

Ordering Information

Specify model number followed by the applicable code(s).
The order code sequence is:

Model-Options-Warranty

| Option | | Order Code |
|----------|---|-------------|
| Model | Single Port Bollard Mount | CT4011 |
| | Dual Port Bollard Mount | CT4021 |
| | Single Port Wall Mount | CT4013 |
| | Dual Port Wall Mount | CT4023 |
| Warranty | Parts Only Extended Warranty - 2, 3, 4, or 5 year | CT4000-EWn* |

* Substitute *n* for the duration of the warranty (2, 3, 4, or 5 year)

Order Code Examples

| If ordering this | the order code is |
|--|--------------------------|
| Dual Port Bollard Mount USA Gateway Station | CT4021-GW1 |
| Single Port Wall Mount Station with 5 Year Warranty | CT4013 CT4000-EW5 |
| Dual Port Wall Mount Canada Gateway Station with 2 Year Warranty | CT4023-GW2 CT4000-EW2 |

CT4023 Wall Mount charging station

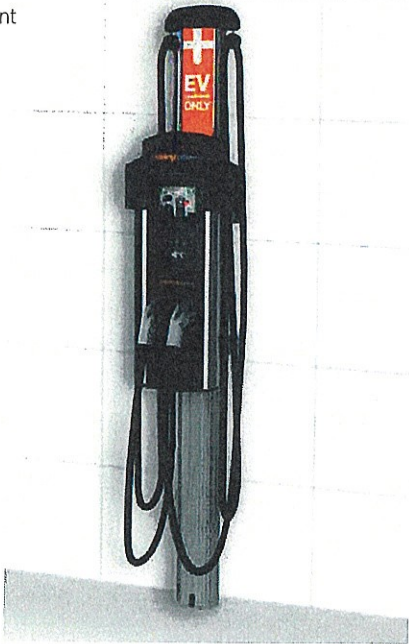

ChargePoint Pty Ltd
74 Mentmore Ave | Rosebery NSW | 2018 AU
1300 300 885
chargepoint.com.au

Copyright © 2013 ChargePoint, Inc. All rights reserved. CHARGEPOINT is a U.S. registered trademark/service mark, and an EU registered logo mark of ChargePoint, Inc. All other products or services mentioned are the trademarks, service marks, registered trademarks or registered service marks of their respective owners. PN 73-001020-01 Rev 4



Listed by Underwriters Laboratories Inc. US LISTED